

FOOD PACKAGING  
line **BABY FOOD & MOUSSE**  
line **CASE READY**  
line **COFFEE**  
line **CONVENIENCE FOOD**  
line **DAIRY**  
line **FRESH SALAD**  
line **PET FOOD**  
line **PROCESS MEAT**  
line **READY MEALS**  
line **SOUP & SAUCE**



**G. MONDINI**

# Complete systems integration that delivers **PERFORMANCE** and **SECURITY**

At G Mondini we have been designing and building complete tray sealing solutions for customers all over the world for over 40 years. Our commitment to line performance, quality of design, engineering standards, innovative ideas on integration and a non negotiable approach to product safety give piece of mind to all our customers.

Each customer project is a journey from an idea or concept through to production reality where the total systems approach and experience of G Mondini brings value to our customers and their customers.

As a family owned business each project is a statement of the company. We pride ourselves in working closely with all participants of the project, understanding individual needs, working in an open and collaborative way to ensure success.

Creativity and Innovation in system design are core competences of our business obliging us to look at each project with 360° vision. This approach ensures our attention to the fine details that make all the difference are addressed and included ensuring the final result.

# SECURITY

The unique construction of Mondini tray sealers delivers unequaled sealing quality ensuring product integrity throughout the functional life of customer's products

# EXPERIENCE

Over forty years of experience means we understand the packaging process, what questions to ask, what will work and how to dominate the fine detail that makes the difference

# PERFORMANCE

Driven by the Mondini TRAVE Platform technology the systems approach delivers world leading line speeds without compromise on the pack security and performance

# FLEXIBILITY

Designed with flexibility in mind, the PLATFORM technology includes a host of attributes allowing our tray sealing lines to benefit our customers to be able to quickly respond to changing market needs.



# line **BABY FOOD & MOUSSE**

packaging solutions **born from experience**

## PROCESS LINE

*A system designed to deliver absolute safety and security during all points in the packaging process. The unique sealing unit in the TRAVE tray sealer ensures the product is perfect from the first pack to the last pack all day every day.*

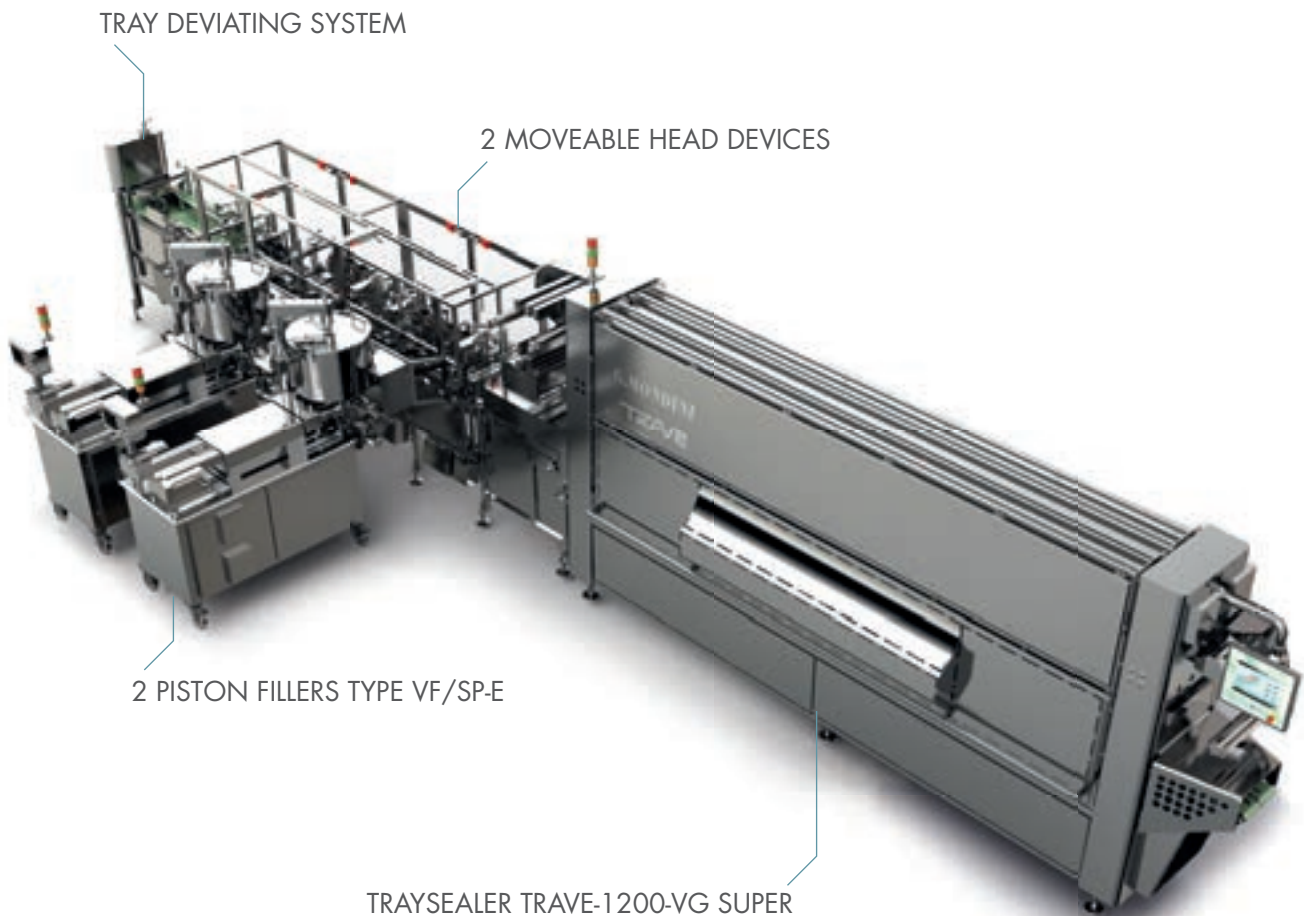



# line CASE READY

making a case for case ready

## PROCESS LINE

*Our innovations in package design, flexibility, productivity and pack security into the Case Ready concept have been a major contributor in the retail growth of fresh meat, fish and poultry.*

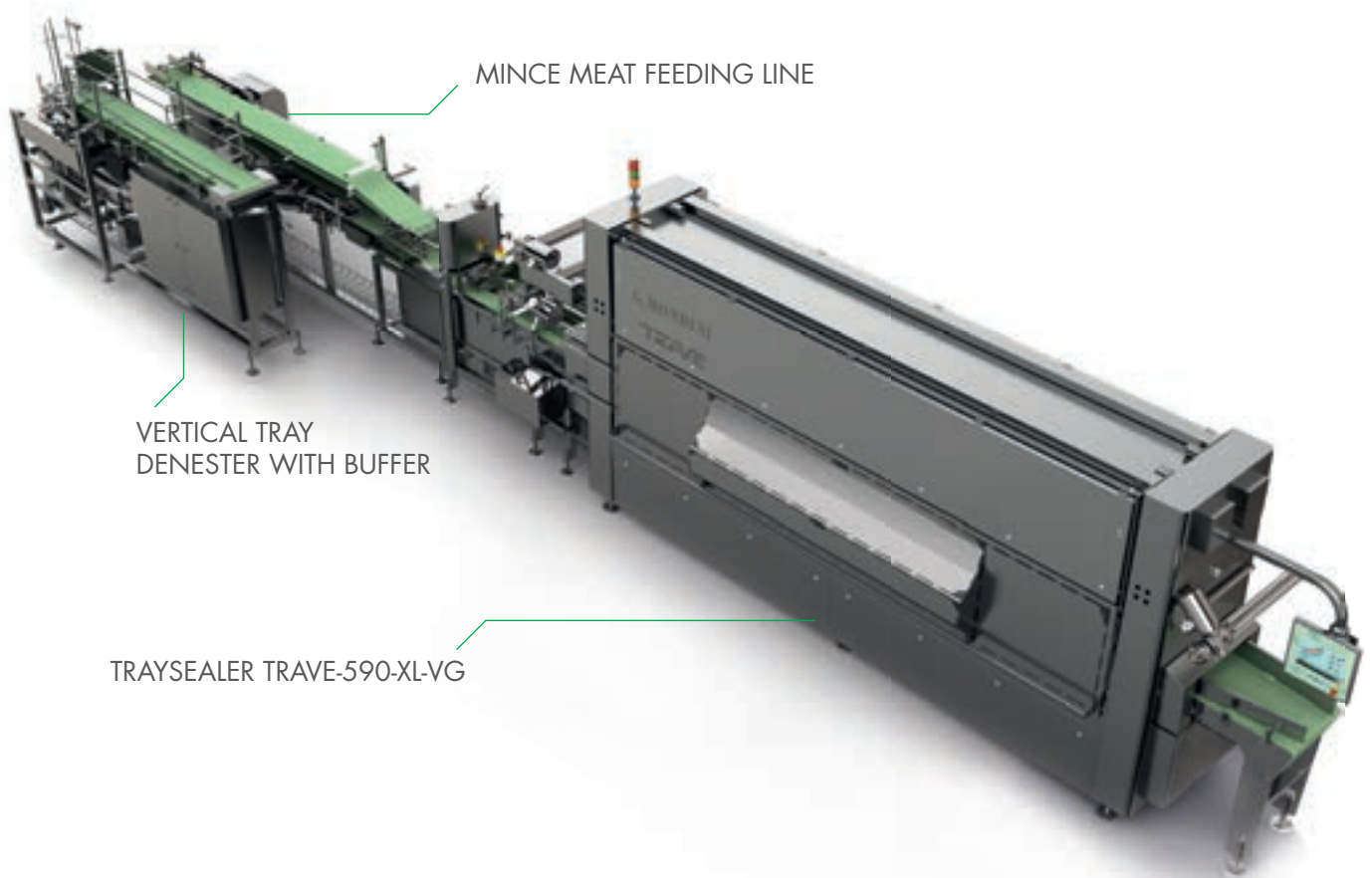

MINCE MEAT FEEDING LINE

VERTICAL TRAY  
DENESTER WITH BUFFER

TRAYSEALER TRAVE-590-XL-VG





# line COFFEE

wake up to the **possibilities**

## PROCESS LINE

*Superior levels of performance with unrivalled reliability put these systems top of the league securing the final product that taste good to everyone.*

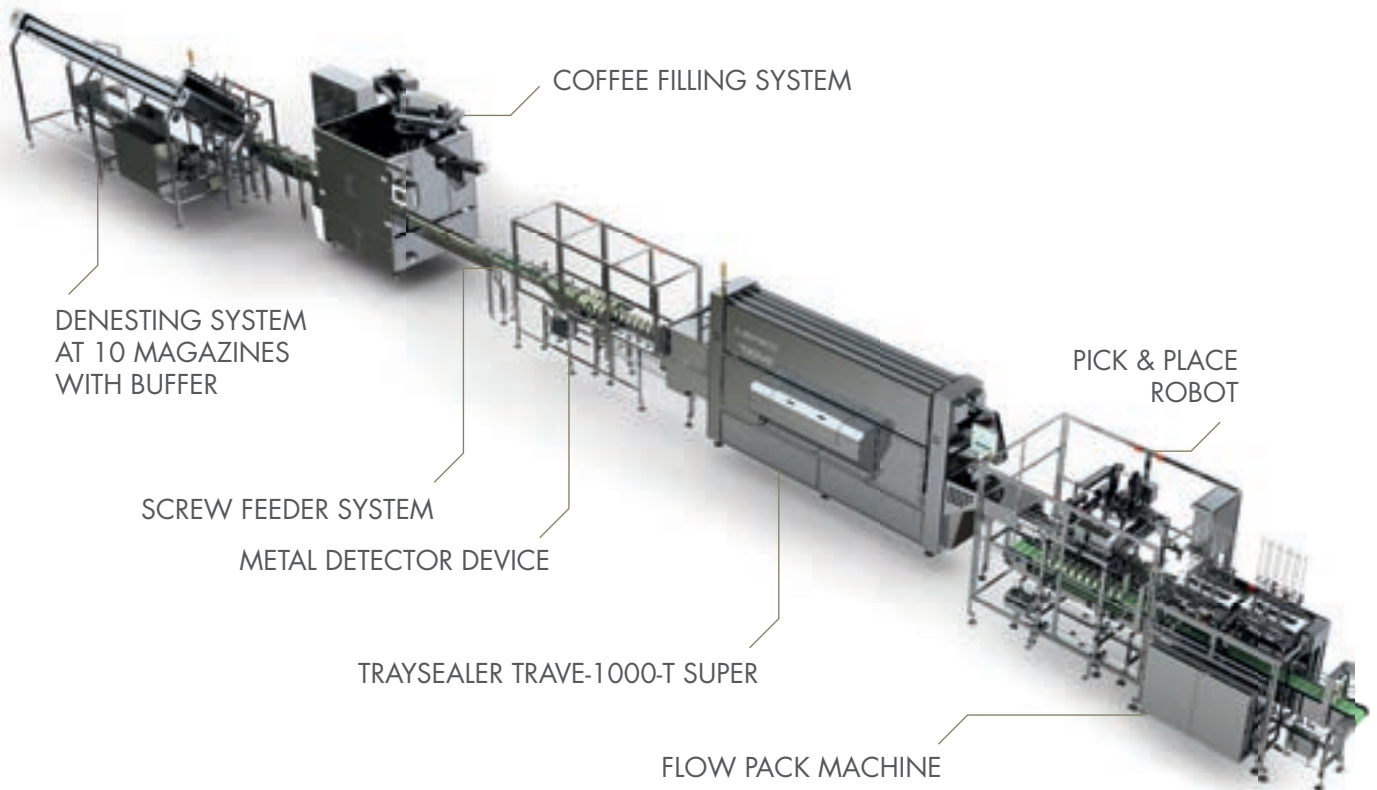



line



# CONVENIENCE FOOD

high speed solutions that keep healthy a bottom line

## PROCESS LINE

*Convenience in harmony with speed and flexibility that satisfies the most demanding customer applications without compromise of performance or security, systems that are built to surpass and surprise.*

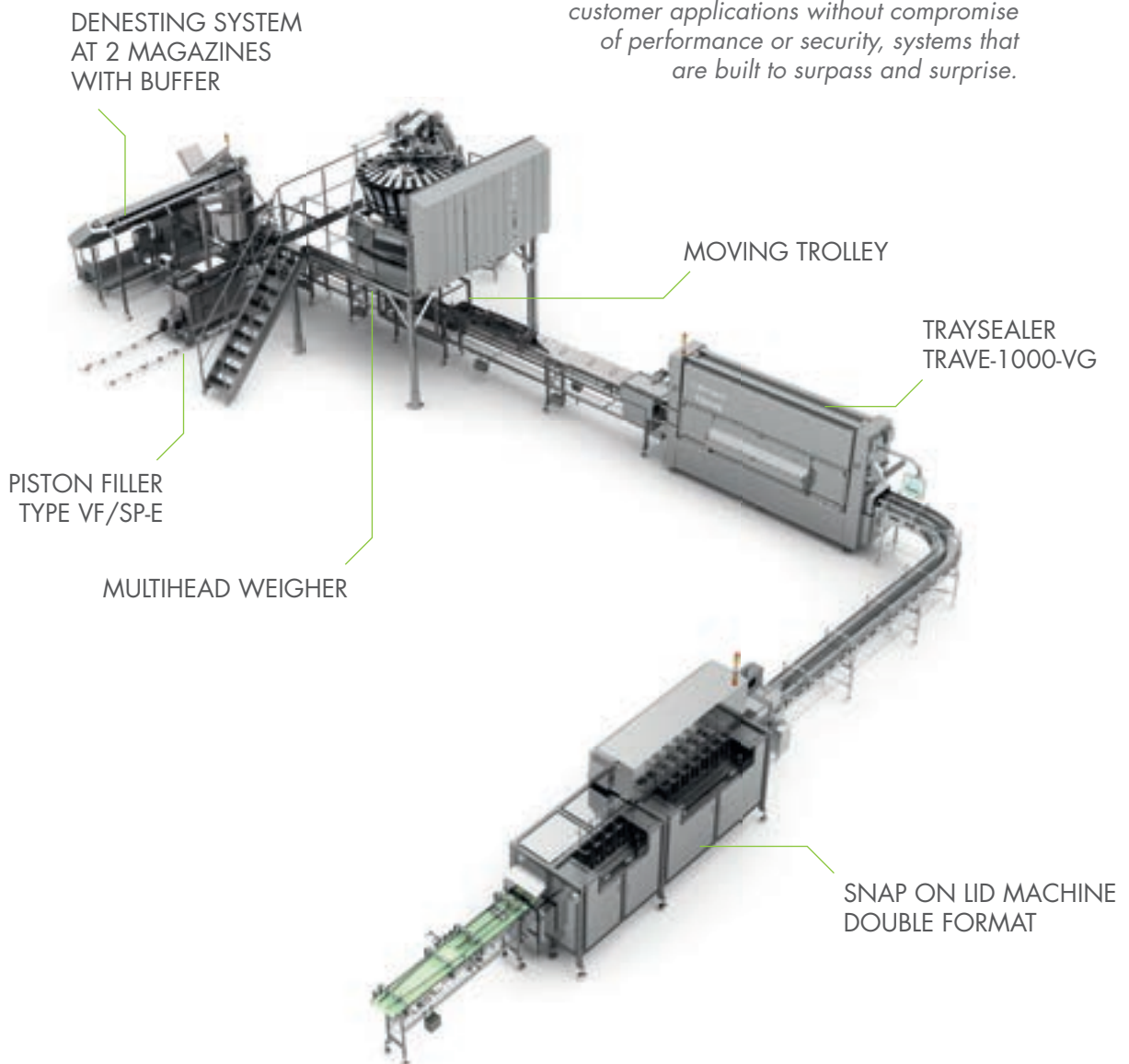



# line DAIRY

**innovative** packaging concepts

## PROCESS LINE

*Unique package features combined with systems automation and performance delivers the almost perfect solution in packaging of cheese chunks and slices.*

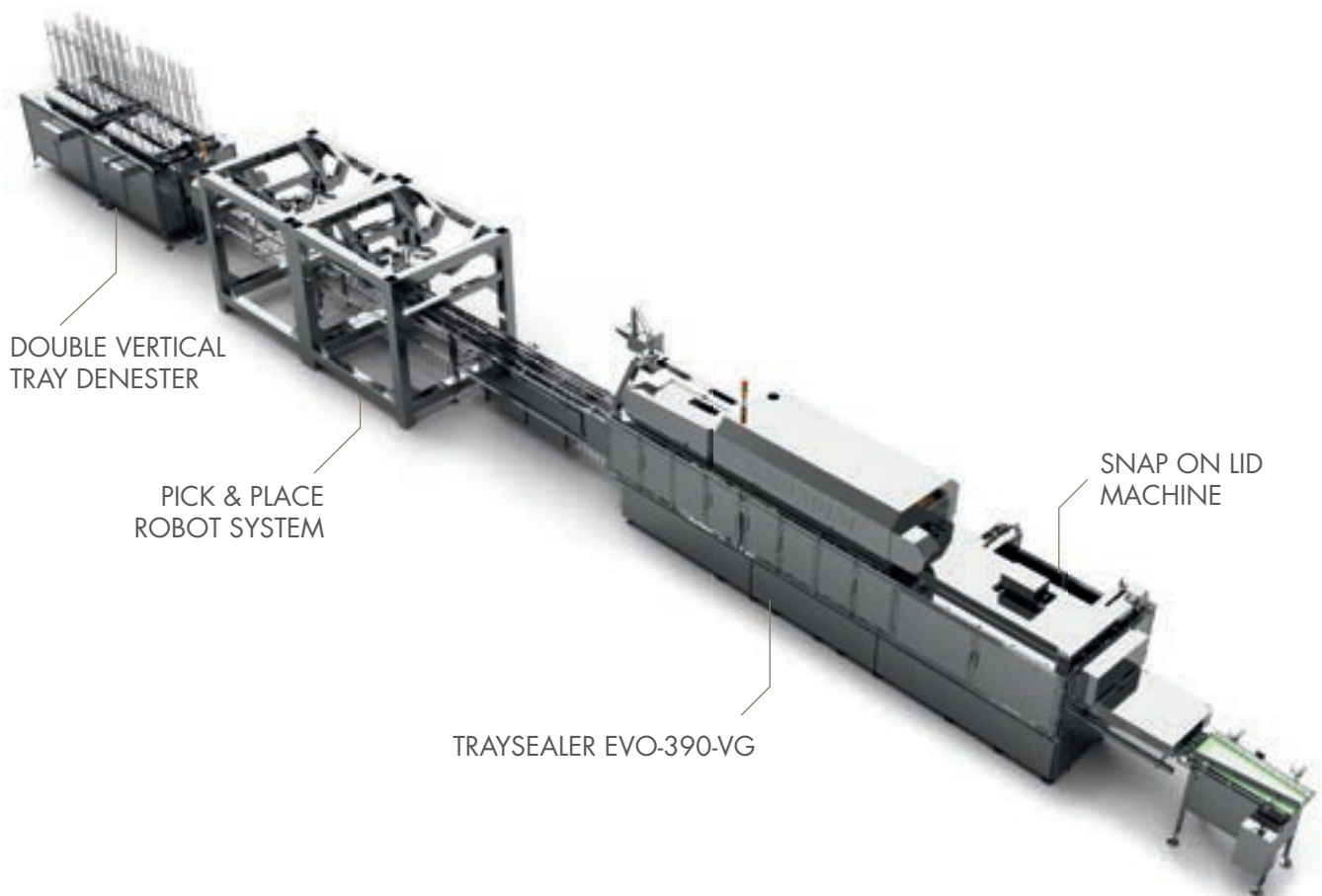



# line FRESH SALAD

## fruits & vegetables

keeping Mother **Nature intact**

### PROCESS LINE

*Innovation and Creativity bringing fresh ideas into the packaging operation whilst maintaining the attention on line performance.*

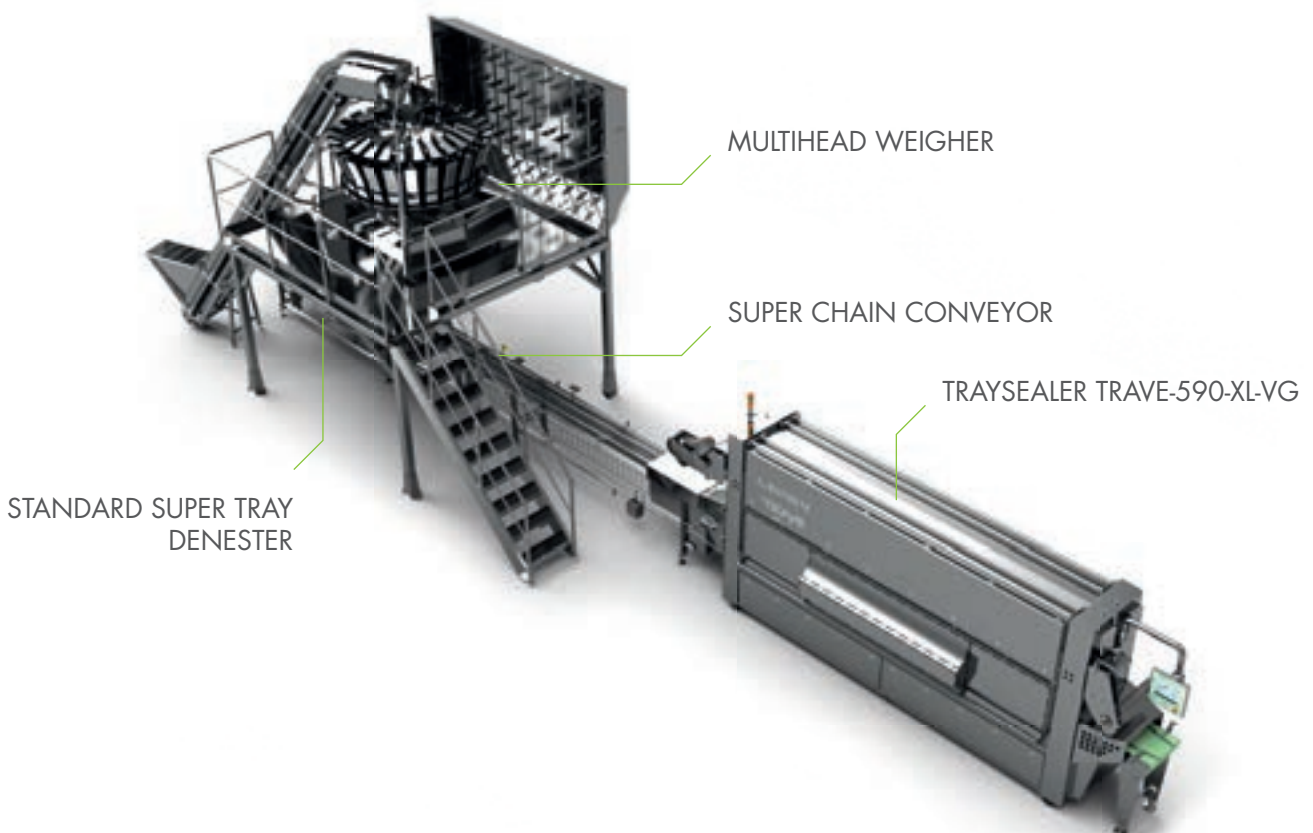





# line PET FOOD

create lasting relationships **with your customer**

## PROCESS LINE

*Years of experience and understanding in systems integration resulting in solutions that create secure packages whilst allowing flexibility to give choice and appeal to the final customers.*

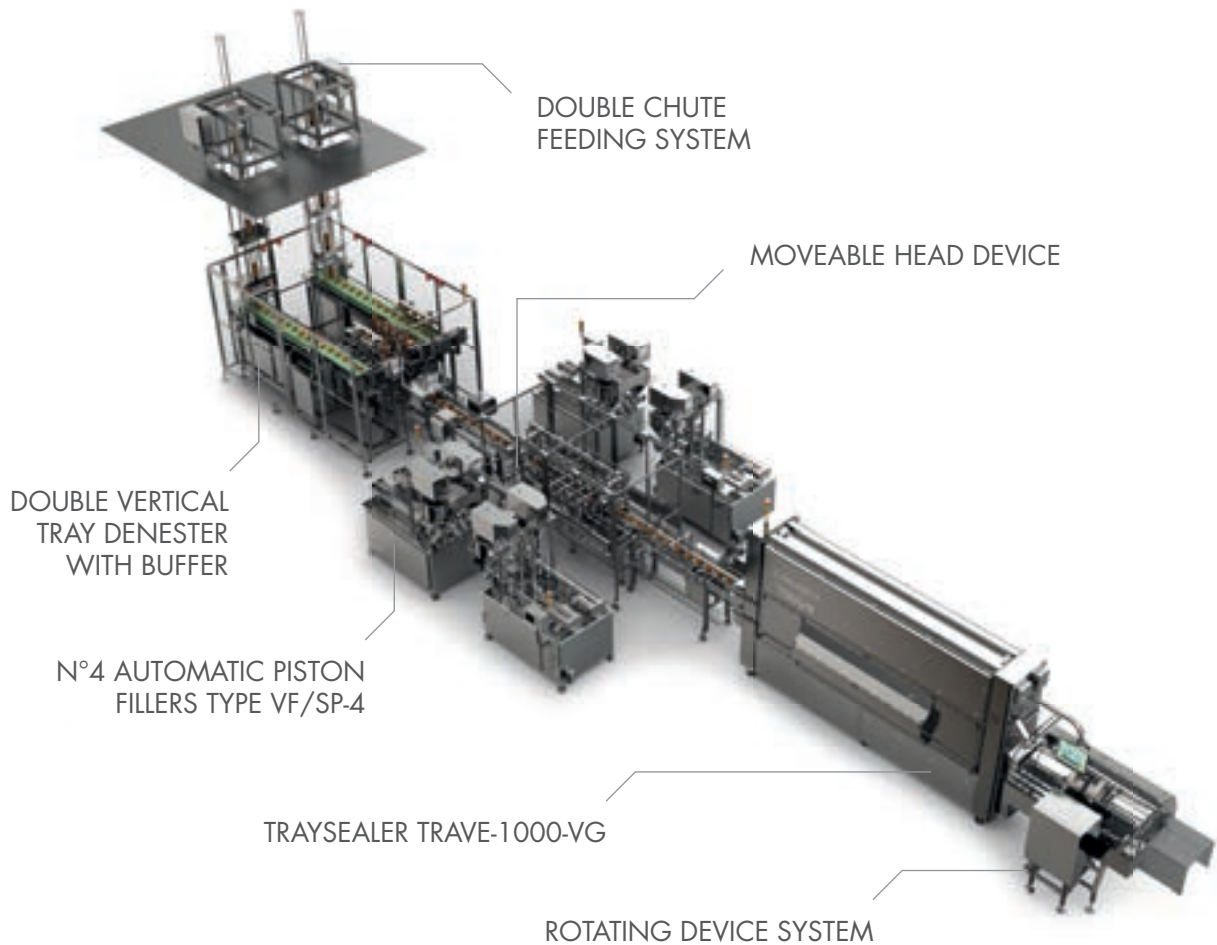



# line PROCESSED MEAT

old world tradition meets **new world technology**

## PROCESS LINE

*Tray sealing systems that enhance sliced products with innovative technology while maintaining their consumer appeal. A focus on line performance with emphasis on production data is a key driver behind these line solutions.*

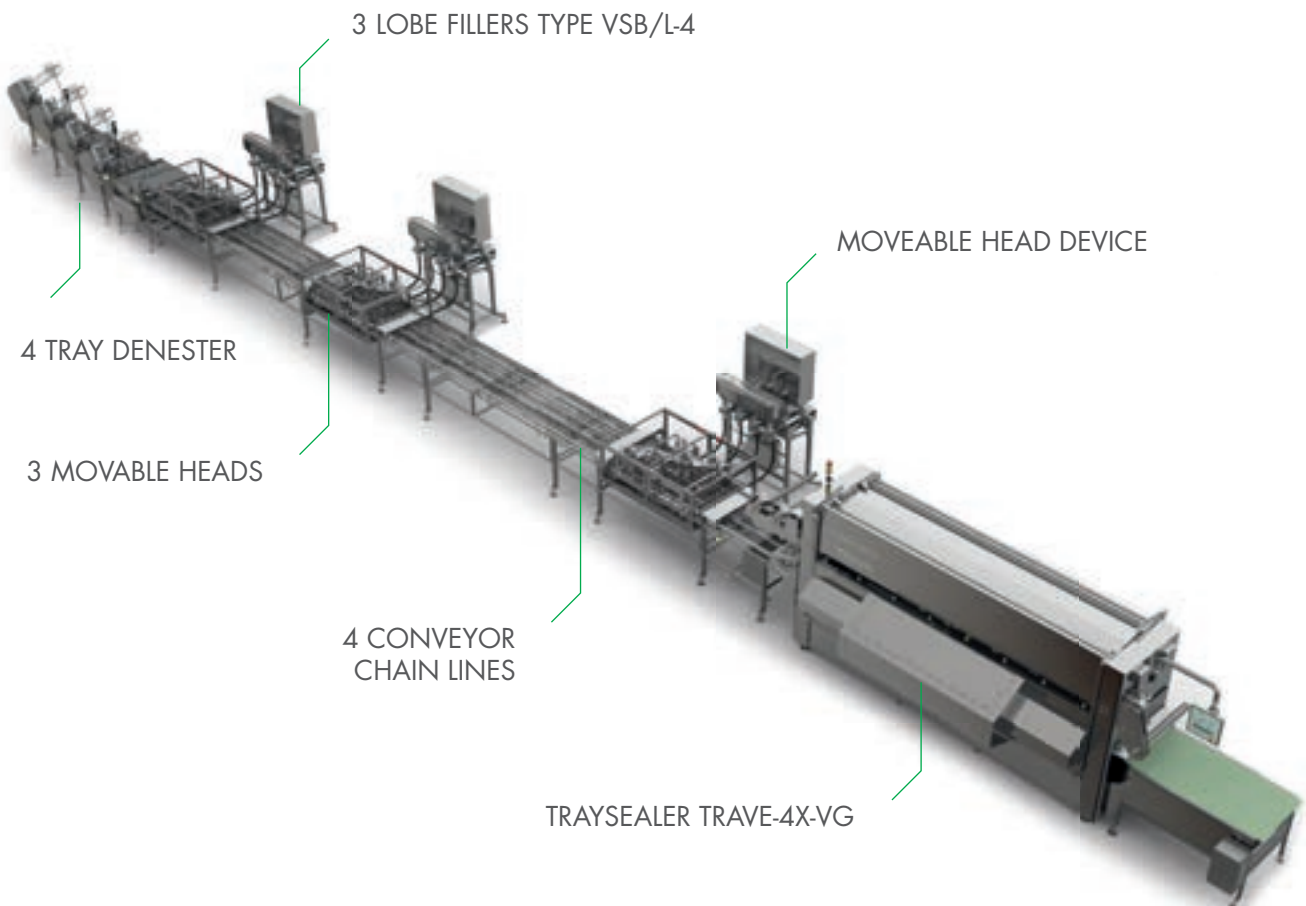



# line READY MEALS

delivering a recipe for success

## PROCESS LINE

*Handling liquids to solids securely with no product outside our experience. Know how and experience built over many years delivering detailed and demanding product specifications to achieve remarkable results for customers.*

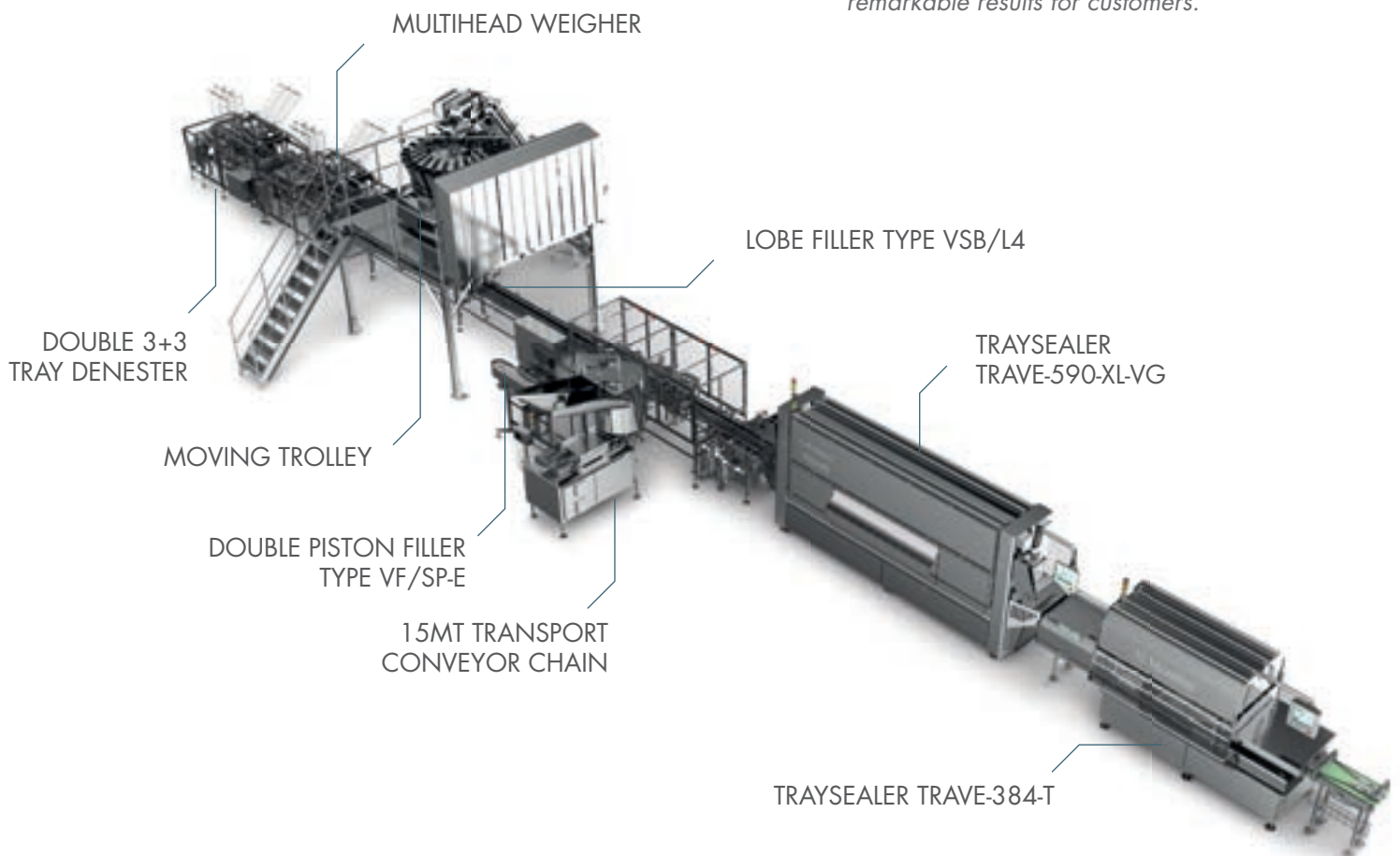



# line SOUP & SAUCE

innovative and unique system

## PROCESS LINE

*A broad range of filling and packaging solutions developed for diverse and technically demanding products.  
Systems that deliver a range of flexible production lines and options securing pack integrity and performance.*

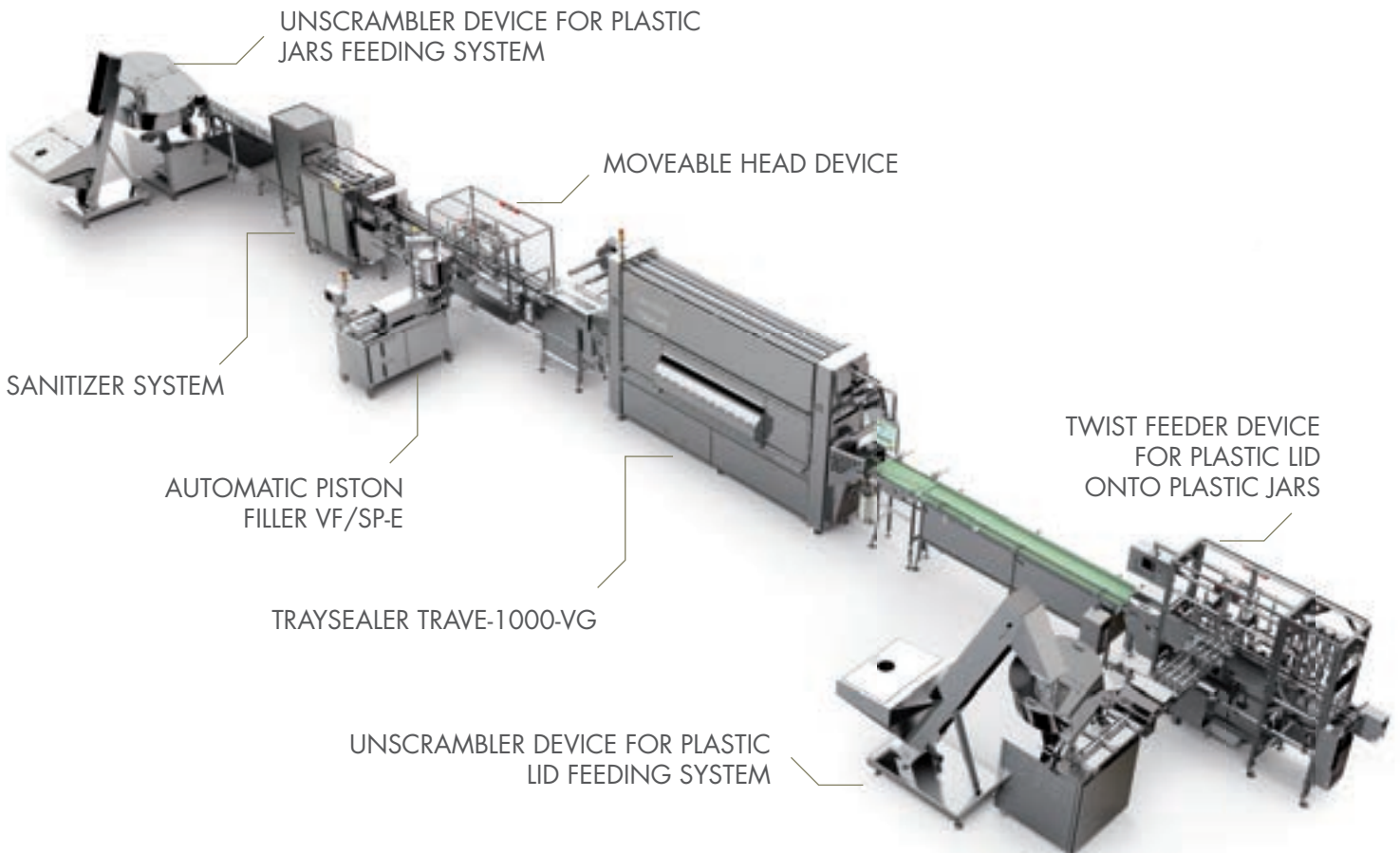

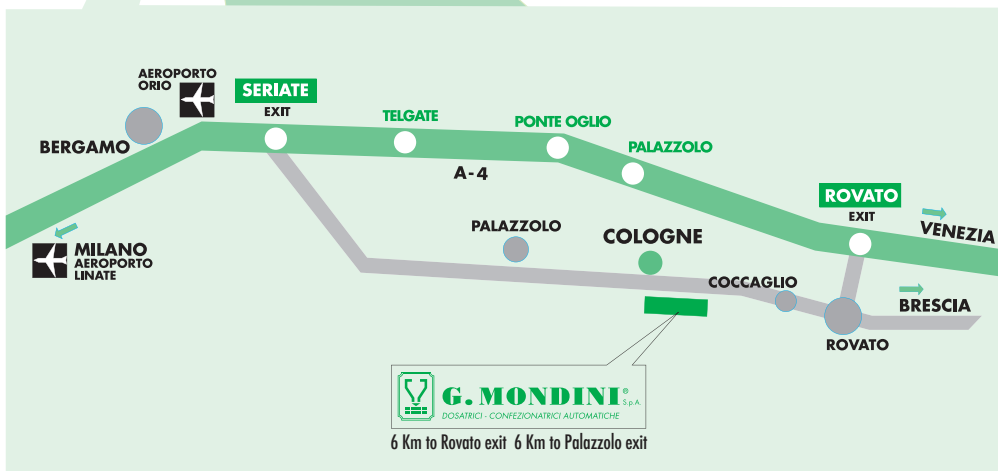

**G. MONDINI**<sup>®</sup> S.p.A.  
DOSATRICI - CONFEZIONATRICI AUTOMATICHE

Via Brescia, 5/7 - 25033 Cologne (Brescia) Italia  
T +39 030 70560 - F +39 030 7056250  
E-mail: info@gmondini.com - [www.gmondini.com](http://www.gmondini.com)